



Excellence since 1928

14_{lb} & 28_{lb}

Heavy Duty Potato Peeling Machines

METCALFE 14lb (6.3kg) & 28lb (12.6kg) PEELERS

The Metcalfe heavy duty potato peeling machines are available in two capacities, 14lb (6.3kg) and 28lb (12.6kg). Both machines can be supplied with a direct gear driven motor or a belt drive. To further meet the requirements of any establishment, the machines are also available as a standard height model or sink height model. The peelers comply with all relevant safety standards. These machines are designed to enable the user to operate, clean and maintain with the minimum of effort.

Metcalfe offer a comprehensive 1 year warranty and a responsive after sales service.

GUARDED DISCHARGE CHUTE (Patent no: 2013815)

As designers and patent holders of the guarded discharge chute we are pleased to confirm that our innovation is in full compliance with the requirements of the Health and Safety at Work Act, 1974. The guard protects the operator by allowing the door to the chamber to be opened which simultaneously stops hand access through the door aperture whilst the machine is working.



28lb
sink height

14lb
standard height



Guarded
discharge chute



CONSTRUCTION

Metcalfé machines are constructed with rust proofed steel pedestals and cast aluminium bases, spindle housings, peeling chambers and tops. The castings are made from a non-corrosive, malleable and ductile aluminium alloy, especially made for direct contact with food, and is impervious to brine, starch and mild acids. The peeling chamber is fitted to the spindle housing with four equidistantly spaced lugs so that the position of the discharge chute in relation to the waste outlet can be fitted in any one of four positions. A rubber gasket is fitted to seal the joints so that the changing of position can be carried out by anyone at any time. The main drive shaft runs in ball races in a large grease chamber; and special oil seals are fitted to each end to prevent water getting in or grease getting out, thereby ensuring complete lubrication. A single point lubricator is fitted, and a half turn every week is all that is required to completely lubricate the machine. Metcalfé machines are smart in appearance, easy to clean, and require minimum maintenance.

HEIGHT

The machines can be supplied standard height or sink height. The latter puts the discharge chute at sink height eliminating the need to mount the machine on a plinth therefore, making installation and cleaning much easier.

DRIVE

The machines can be supplied with either vee belt or gear drive.

BELT DRIVEN

The vee belt driven machines have a single belt and 1/3 h.p. motor on the 14lb (6.3Kg) models, and twin belts and 1/2 h.p. motor on the 28lb (12.6Kg) models. The motor is housed outside the pedestal under a streamlined cover, with easy access for servicing and replacing belts. A simple belt tensioner is fitted on the outside so that the belts can be easily tightened.

GEAR DRIVEN

The 14lb (6.3Kg) capacity model is fitted with 1/3 h.p. and the 28lb (12.6Kg) with 1/2 h.p. geared units. The motor and gearbox units are housed inside the pedestal so that there are no external projections. This is a composite unit which is grease packed before leaving the works, and therefore requires little attention. The drive between the output shaft of the unit and the drive shaft of the peeler is by means of a flexible coupling which will prevent damage to the motor or the gearbox if the machine is accidentally jammed or overloaded.

CLEANING

The top of the peeling chamber lifts off so that the rotor plate can be removed with the two lifting hooks, thereby exposing the whole of the chamber and waste outlet, which can then be easily and thoroughly cleaned. The rotor plate is an aluminium casting with a cast iron centre, and is light and easy to remove. The whole operation which takes only a few minutes should be done daily.

ABRASIVE

The rotor plate has been bonded with abrasive grit. The inside wall of the peeling chamber has cast-in abrasive serrations (Patent no. 1,016,390) which dispense with the need for abrasive coating. It has been proved that there is considerably less loss of potato, both during peeling and boiling, when peeled in this type of machine. There is positively no difference in peeling time and the efficiency of the serrations will last the life of the machine.

There are many advantages with Metcalfé peelers e.g. the peeling chamber never needs recoating, therefore machines are never out of action whilst this is being done and all additional expenses involved such as transport and loan of machines are eliminated. This feature is exclusive to our machines, and has been thoroughly tried and approved by the various Ministry Departments, Education Authorities and other major establishments in the United Kingdom.

If a customer feels an additional need for the peeling chamber to be coated with abrasive, this could be done, but the application is unnecessary.

FINISH

Metcalfé potato peeling machines are finished in a high gloss catalysed enamel in silver grey hammer. The top of the machine is a brightly polished aluminium casting which improves the appearance of the peeler, and cannot be chipped by buckets, etc., as would happen if it were painted.

ELECTRICAL CONNECTION

All 14 & 28lb pedestal peelers should be connected to the main electrical supply via a wall mounted contactor. We recommend a wall mounted starter incorporating an emergency stop button, no-volt release and overload protection. A 13amp wall socket is not acceptable and connection such will invalidate the warranty.

WATER SUPPLY

The machine is fitted with a suitable water inlet and hose connection incorporating an air break. A stop tap can be fitted to the machine if required. Provision is made so that the water inlet can be fitted on either side of the machine to suit the particular installation.

WASTE OUTLET

The waste outlet is screwed 2in. B.S.P. female as shown on the line drawing.

SLUDGE DISPOSAL

The waste disposal adaptor dispenses with the need for an interceptor. This unit gives an adequate water supply to the peeling chamber, and additional water supply to the waste outlet. A sweep tee is fitted to the waste outlet, and the additional supply is directed into it so that the sludge is flushed away. The unit is supplied complete so that it is only necessary to connect one water supply to it. Water Byelaws Scheme - Approved product when connected to water header tank.

External or built-in interceptors can be supplied as alternatives.

The external interceptor consists of a steel tank and woven wire basket, rust proofed after manufacture. The outlet from the tank is screwed 2in. (5cm) B.S.P. The built-in interceptor consists of a sealed tank fitted inside the pedestal of the machine with a front opening through which the basket is inserted and removed. A plate with a rubber gasket is attached to the basket which covers the hole when the machine is in use and prevents any splashing. Two chromium plated handles are fitted for removing. The interceptor is so constructed that if the basket was not emptied there is no possibility of the sludge coming back into the kitchen.

METCALFE WASTE DISPOSAL ADAPTOR

Approved by the Water Research Council

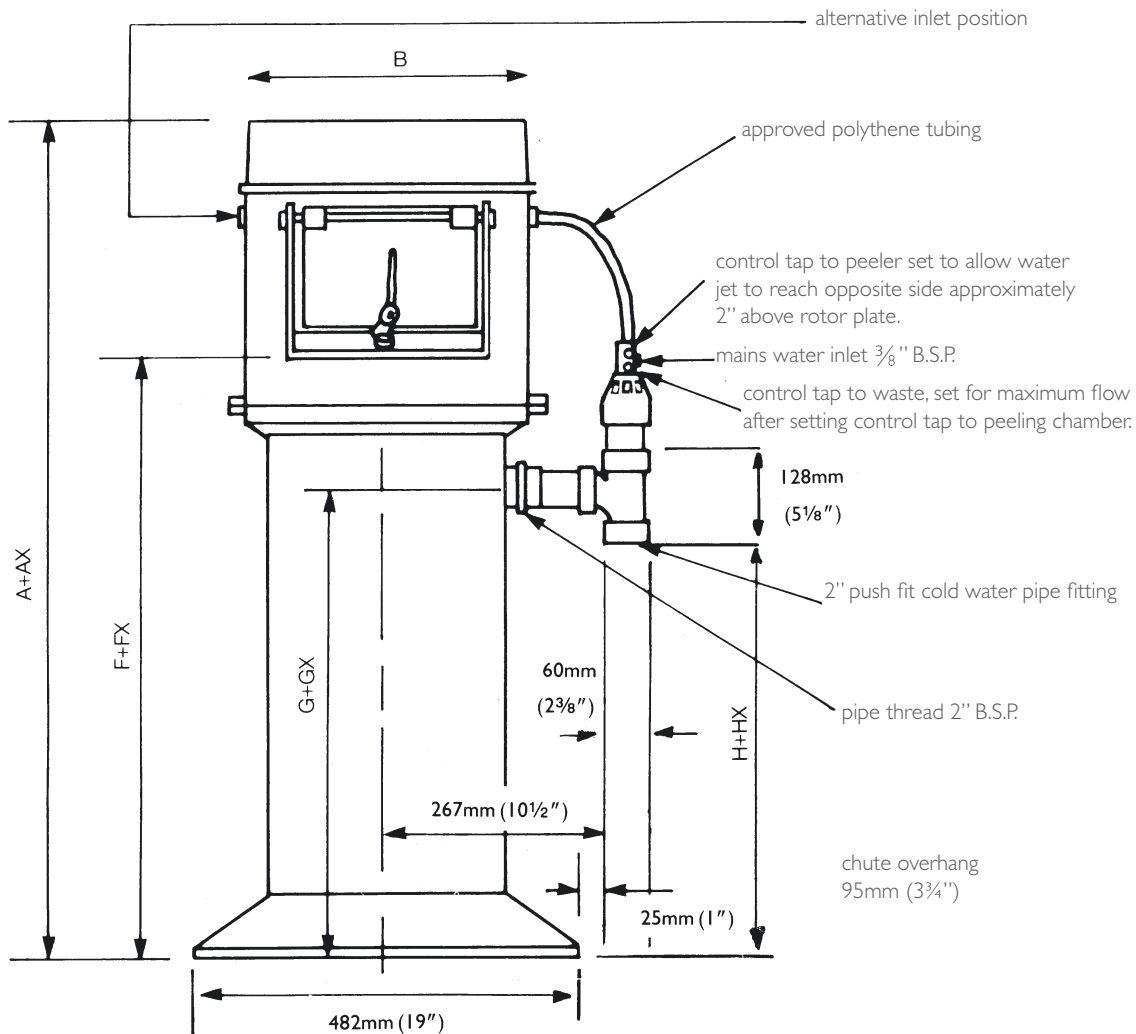

ALL DIMENSIONS SHOWN ON PANEL OVERLEAF.



GEAR DRIVEN MACHINES

BELT DRIVEN MACHINES

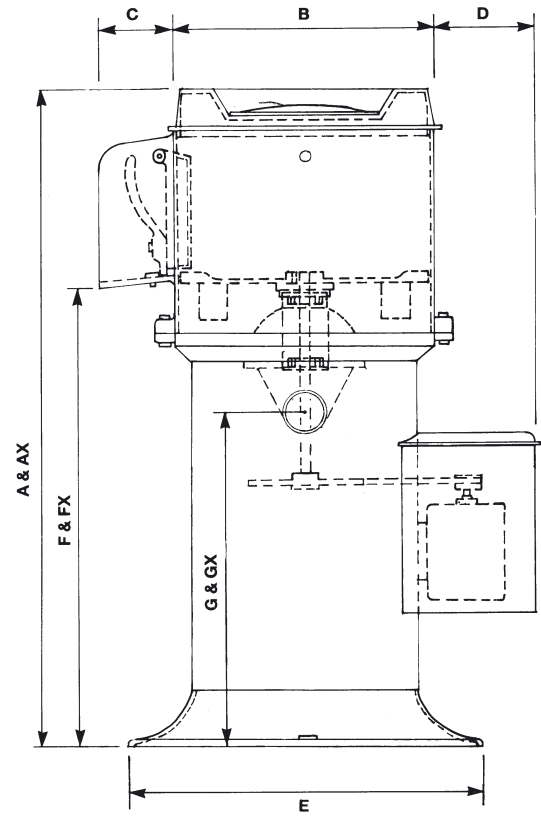
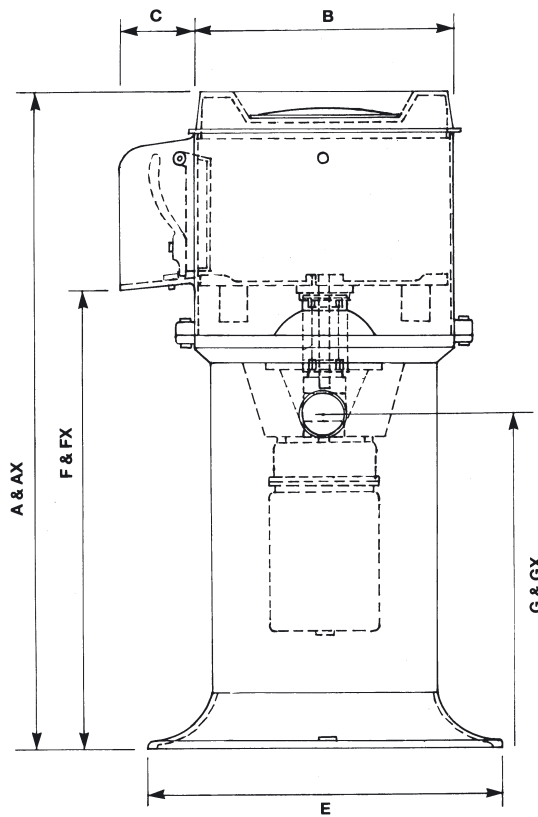

AX, FX, GX, HX show measurements for sink height pedestals for sinks 915mm (36") high - other heights can be supplied to order.

DIMENSIONS												
	A	B	C	D	E	F	G	H	AX	FX	GX	HX
6.3kg 14lb	900mm 35½"	370mm 14½in	85mm 3¾"	200mm 8"	480mm 19"	635mm 25"	450mm 17¾"	381mm 15"	1205mm 47½"	940mm 37"	765mm 29¾"	686mm 27"
12.6kg 28lb	930mm 36¾"	460mm 18"	100mm 4"	16cm 6½"	480mm 19"	640mm 25½"	460mm 18"	381mm 15"	1245mm 49"	940mm 37"	755mm 29¾"	686mm 27"

DIMENSIONS FOR MACHINES WITH GUARDED DISCHARGE CHUTE ARE AS ABOVE, BUT GUARD EXTENDS BEYOND END OF CHUTE BY 100mm (4").

Stockists:

Metcalfe Catering Equipment Ltd

Haygarth Park, Blaenau Ffestiniog, Gwynedd,
LL41 3PF, Great Britain

t +44 (0)1766 830 456

f +44 (0)1766 831 170

e enquiries@metcalfecatering.com

w www.metcalfecatering.com

 Proudly made in the UK