



Excellence since 1928

EPC

ELECTRICALLY OPERATED
POTATO CHIPPING MACHINE

METCALFE EPC

The Metcalfe EPC rotary action electrically operated chipping machine has been designed for high volume production of chips and/or potato scollops and will produce approximately 30/40lb (14/18kg) of chips per minute. Standard size of chip is 1/2" (12.5mm), but by simply exchanging the rotor and chipping unit, chips of 5/8" (15mm), 3/8" (10mm) or 5/16" (8mm) can be produced and also potato scollops. (Other sizes available to special order.)



BENCH MOUNTED MODEL

Also available with trolley.

CLEANING FEATURES

This illustration shows the machine completely dismantled for cleaning. Only three items have to be removed, the stainless steel hopper, the chipping unit, and the potato rotor. The rotor is held in position by one large nut and is removed by unscrewing with the large tee wrench provided.



CONSTRUCTION

MAIN BODY

Strong, rigid angle iron frame of welded construction, enclosed by steel panels finished either in polychromatic grey paint or completely in stainless steel.

BULK FEED HOPPER

Strong, rigid angle iron frame of welded construction, enclosed by steel panels finished either in polychromatic grey paint or completely in stainless steel.

ROTARY FEED AND CHIPPING UNIT

Stainless aluminium alloy castings impervious to vegetable juices and starch stains etc.

SAFETY

All moving parts are enclosed and an automatic switch is built-in which breaks the electrical circuit when the machine is opened. The machine cannot therefore be operated unless the chipping unit is correctly positioned and in the closed position. This is to comply with the provisions of the Health and Safety at Work Act 1974.

ELECTRICAL PROTECTION

The machine is fitted with a No-Volt Release Device Relay built into the internal wiring giving full protection irrespective of where the machine is used. This device prevents the machine starting should the power be interrupted and then restored. An overload button is also incorporated in the motor circuit.

MAINTENANCE

The motor, gearbox and all bearings are grease-packed and sealed and require no maintenance. All that is necessary is to keep the cutting knives sharp.

MOBILE STAND/TROLLEY

The stand/trolley is constructed of tubular steel with heavy angle iron platform. Castors on the two front legs enables the machine to be easily wheeled away for storing, and rubber feet on the two rear legs ensure it is completely stable and will not move whilst in use.

The overall height of the stand/trolley will give the height of the discharge of chips at 82cm. (32") but any other height can be produced to special order.

OVERALL DIMENSIONS:

Length 800mm
Width 380mm
Height 480mm

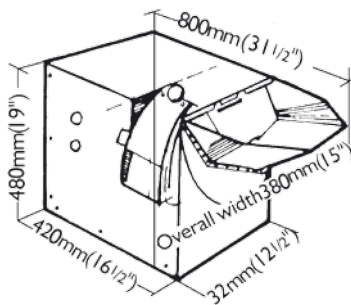

MOBILE MODEL

Illustrated is the specially designed Stand/Trolley allowing the EPC Chipper to be operated as a mobile machine.

OVERALL DIMENSIONS:

Length 660mm
Width 430mm
Height 460mm

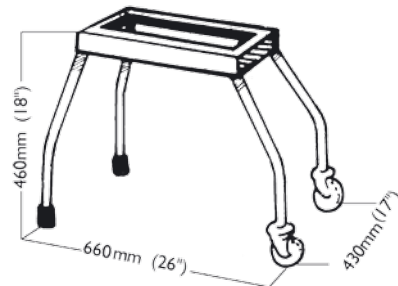

Stockists:

Metcalfe Catering Equipment Ltd
Haygarth Park, Blaenau Ffestiniog, Gwynedd,
LL41 3PF, Great Britain
t +44 (0)1766 830 456
f +44 (0)1766 831 170
e enquiries@metcalfecatering.com
w www.metcalfecatering.com
 Proudly made in the UK