



**Model**

MP40

**Product Description**

Planetary Mixer, 40 litre, Heavy Duty

**Product Code**

5MP40-1PH

5MP40-3PH

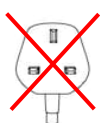

**Standard Features**

- Heavy duty 40ltr, floor standing, gear driven, planetary mixer
- Particularly suitable for bakeries, hotels, restaurants, canteens etc
- Easy to operate
- Planetary mixing action ensures perfect results
- High torque motor allows mixing of stiffer doughs and larger batches
- 3 fixed speeds: 95, 195 and 356 rpm
- Easy speed-shifting
- Timer
- Emergency stop button
- Interlocking bowl guard and bowl lift
- Dual bowl clamps to lock bowl down
- Stainless steel safety guard with ingredient chute and automatic shut-off when guard is opened at any speed
- Resettable thermal overload protection (NVR device)
- Long lasting lubricant providing abrasion resistant transmission
- Transmission gears are made of heat treated, hardened steel
- Heavy duty, cast iron frame
- Non-slip rubber feet
- Quiet operation
- Heavy duty gearbox
- Industry standard #12 attachment hub

**Standard Accessories / Attachments**

- 1 x Whisk
- 1 x Beater
- 1 x Dough Hook
- 1 x 40 litre Stainless steel bowl

**Warranty**

Covered by Metcalfe 3-year warranty (1<sup>st</sup> year parts and labour, 2<sup>nd</sup> & 3<sup>rd</sup> years parts only) and full after sales service.

**Note:** The minimum requirement for all electrical equipment's correct operation is an air temperature of between +5°C and +40°C. Mixers should not be operated in a cold store.

**Optional Attachments**

Item	Product Code
Veg Prep Attachment (no plates included)	MPVS12A

Item	Product Code
Meat Mincer Attachment (6mm & 8mm plates included)	MPG12SH

## Optional Accessories

Item	Product Code
Bowl	MP11040-12-001
Beater	MP11040-12-002
Dough Hook	MP11040-12-003
Whisk	MP11040-12-004
Bowl Trolley	MP11040-12-011

Item	Product Code
20ltr reduction bowl	MP11040-12-001M
20ltr reduction beater	MP11040-12-002M
20ltr reduction dough hook	MP11040-12-003M
20ltr reduction whisk	MP11040-12-004M

## Drawing

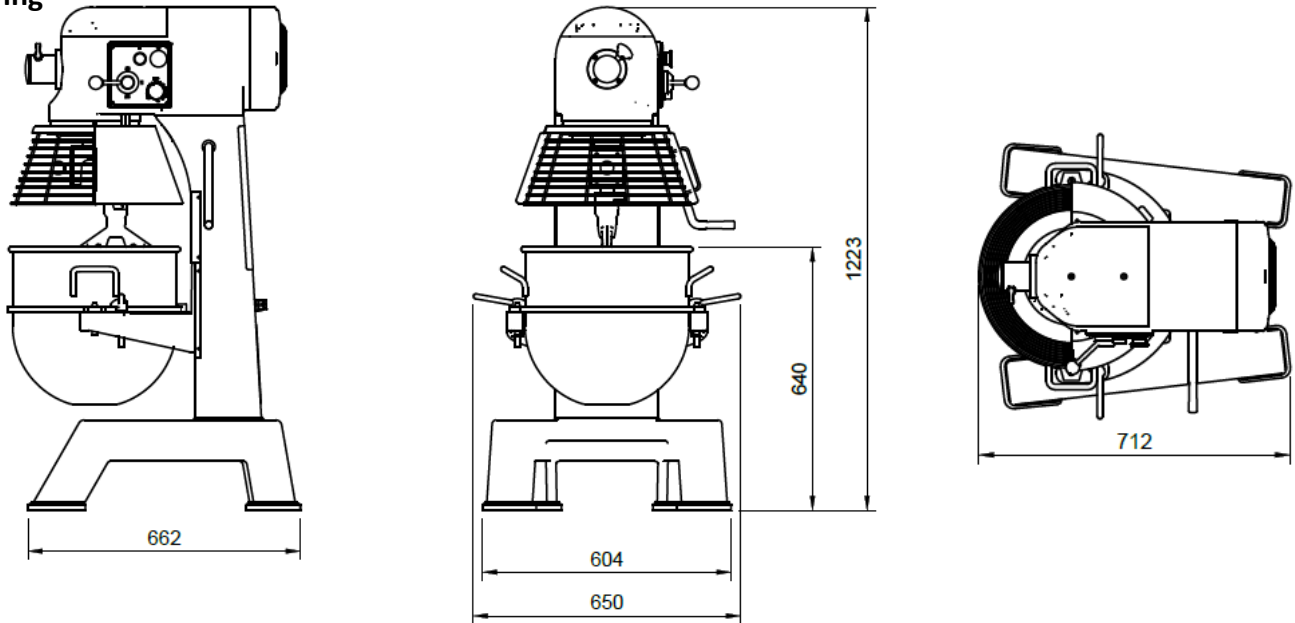

## Specifications

Model	Capacity (ltr)	Phase (Ø)	Motor (Volt)	Frequency (Hz)	AMP (A)	Power (kW / hp)	Speed (rpm)
MP40-1ph	40	1	220-240	50	12	1.125 / 1.5	95 / 195 / 356
MP40-3ph	40	3	380-415	50	2.7 total	1.125 / 1.5	95 / 195 / 356

## Dimensions | Shipping Information

Model	Overall Dimensions D x W x H (mm)	Net Weight (kg)	Packed Dimensions D x W x H (mm)	Packed Weight (kg)	Volume (m3)
MP40	712 x 650 x 1223	205	820 x 720 x 1430	217	0.844

We reserve the right to alter the specification and technical details for this item at any time without prior notice.

1/2024

## Metcalfe Catering Equipment Ltd

Haygarth Park  
Blaenau Ffestiniog  
Gwynedd, LL41 3PF

