



Model

MP30

Product Description

Planetary Mixer, 30 litre, Heavy Duty

Product Code

5MP30-1PH

5MP30-3PH

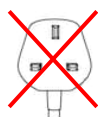

Standard Features

- Heavy duty 30ltr, floor standing, gear driven, planetary mixer
- Particularly suitable for bakeries, hotels, restaurants, canteens etc
- Easy to operate
- Planetary mixing action ensures perfect results
- High torque motor allows mixing of stiffer doughs and larger batches
- 3 fixed speeds: 125, 232 and 423 rpm
- Easy speed-shifting
- Timer
- Emergency stop button
- Interlocking bowl guard and bowl lift
- Dual bowl clamps to lock bowl down
- Stainless steel safety guard with ingredient chute and automatic shut-off when guard is opened at any speed
- Resettable thermal overload protection (NVR device)
- Long lasting lubricant providing abrasion resistant transmission
- Transmission gears are made of heat treated, hardened steel
- Heavy duty, cast iron frame
- Non-slip rubber feet
- Quiet operation
- Heavy duty gearbox
- Industry standard #12 attachment hub

Standard Accessories / Attachments

- 1 x Whisk
- 1 x Beater
- 1 x Dough Hook
- 1 x 30 litre Stainless steel bowl

Warranty

Covered by Metcalfe 3-year warranty (1st year parts and labour, 2nd & 3rd years parts only) and full after sales service.

Note: The minimum requirement for all electrical equipment's correct operation is an air temperature of between +5°C and +40°C. Mixers should not be operated in a cold store.

Optional Attachments

Item	Product Code
Veg Prep Attachment (no plates included)	MPVS12A

Item	Product Code
Meat Mincer Attachment (6mm & 8mm plates included)	MPG12SH

Optional Accessories

Item	Product Code
Bowl	MP11031-12-001
Beater	MP11031-12-002
Dough Hook	MP11031-12-003
Whisk	MP11031-12-004
Bowl Trolley	MP11031-12-005

Item	Product Code
20ltr reduction bowl	MP11031-12-001M
20ltr reduction beater	MP11031-12-002M
20ltr reduction dough hook	MP11031-12-003M
20ltr reduction whisk	MP11031-12-004M

Drawing

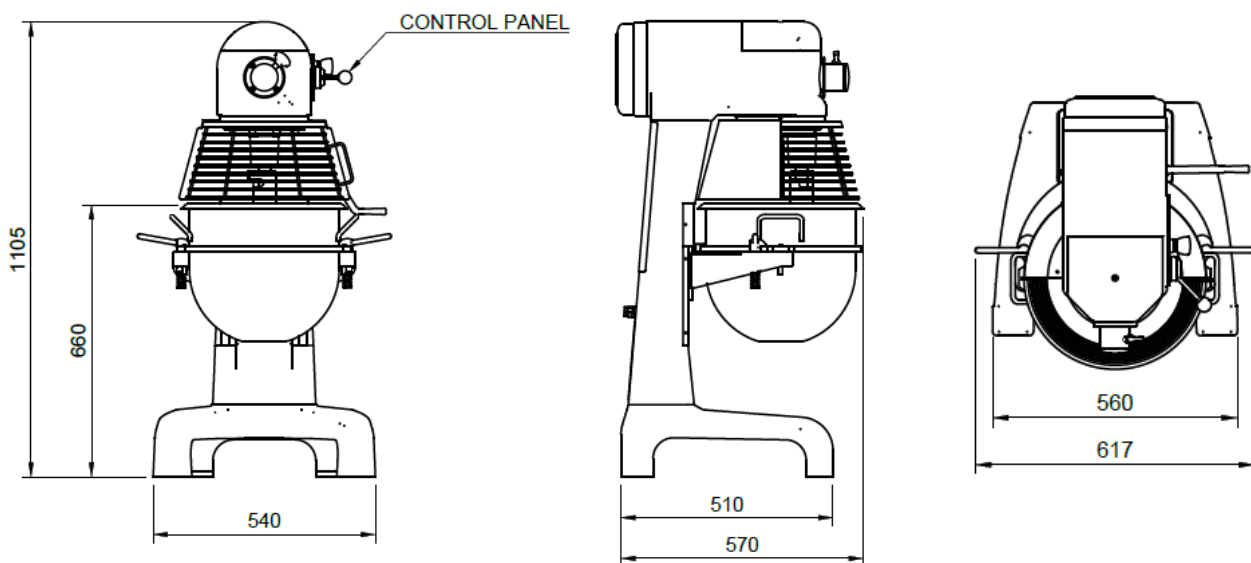

Specifications

Model	Capacity (ltr)	Phase (Ø)	Motor (Volt)	Frequency (Hz)	AMP (A)	Power (kW / hp)	Speed (rpm)
MP30 – 1ph	30	1	220-240	50	8	0.75 / 1	125 / 232 / 423
MP30 – 3ph	30	3	380-415	50	1.9 total	0.75 / 1	125 / 232 / 423

Dimensions | Shipping Information

Model	Overall Dimensions D x W x H (mm)	Net Weight (kg)	Packed Dimensions D x W x H (mm)	Packed Weight (kg)	Volume (m3)
MP30	570 x 617 x 1105	185	700 x 600 x 1280	197	0.538

We reserve the right to alter the specification and technical details for this item at any time without prior notice.

1/2024

Metcalfe Catering Equipment Ltd

Haygarth Park

Blaenau Ffestiniog

Gwynedd, LL41 3PF

