



Manufactured By



Instruction Manual

FREESTANDING ELECTRIC HOTPLATE & TOASTER



AHT860

Version 6

CONTENTS

Product Features	2
Specifications	2
Parts Included	2
Safety Instructions	2
Cleaning & Maintenance	3
Installation	4
General Information	5
Operation	7
Workstation Layout	8
Troubleshooting	8
Thermal Cutouts	9
Spare Parts	10
Circuit Diagram	11
Warranty	Error!

Bookmark not defined.

PRODUCT FEATURES

- High Temperature Capacity
- Durable Stainless Steel Elements
- 12mm Steel Hotplate
- Adjustable Legs & Rear Castors
- Easy Cleaning Grease Over-Spill Box
- Digital LED Temperature Display
- Independently Controlled Grill
- Cook/Idle Selector Switches

SPECIFICATIONS

Model	Power (400VAC)	Size (mm)			Kg
		W	D	H	
AHT860	12.5KW	590	855	1075	120

PARTS INCLUDED

- Electrical Hotplate & Toaster (AHT860)
- Instruction Manual

Any damage to the machine as a result of freight must be reported to the Freight Company and to the agent responsible for the despatch of machine within 24 hours of receipt. No claims will be accepted after this period.

SAFETY INSTRUCTIONS

Read all Instructions and safety warnings prior to use. Keep user manual for future reference.

Service and repair should only be performed by qualified technicians who have read and understood this manual.

Personnel must be trained prior to operating this appliance.

This product is suitable for commercial use only.

This machine should not be operated by persons (including children) with reduced physical, sensory or mental capabilities, or lack of experience or knowledge, unless they have been given supervision or instruction concerning the safe use of the appliance by a person responsible for their safety.

Keep out of reach from children.

Avoid contact with the exterior of this machine as surfaces can get hot.

Do not position appliances where hot surfaces maybe accidentally touched.

The machine should be disconnected from all power and allowed to cool before cleaning or servicing.

Regularly inspect the supply cord/plug and discontinue use immediately if damage is found. Return to manufacturer or authorised repairer for repair prior to use.

This machine contains no user-serviceable parts. Roband®, one of our agents, or a similarly qualified person(s) should carry out repairs.

Keep cord away from heated surfaces.

Do not remove any cover panels from the machine.

Roband Australia will not accept liability if:

- Non-authorized personnel have tampered with the machine
- The instructions in this manual have not been followed
- Non-original spare parts are used
- There is any damage to the unit

These units should NOT be left unattended during operation.

During use, these units heat up and can cause damage or bodily harm if not operated correctly. Ensure proper signage is in place to reduce the risk of any hazards.

GENERAL FIRE SAFETY

Before using any hotplate, adequate safety measures should be in place. Such measures should include, but not be limited to, having an appropriate fire extinguisher or fire blanket located nearby in case cooking oils on the plate ignite. Refer to the appropriate regulations pertaining to your operating environment for details of the correct fire prevention measures required.

SAFETY OF SERVICEPERSONS

Before servicing this machine it is necessary to disconnect all power. These units are NOT fitted with a mains isolating switch. An all-pole disconnection/isolating switch must be mounted and wired *externa* to this machine (see section *ELECTRICAL CONNECTION*). A cooling circuit will remain "live" within these units even when turned "off" at the control panel. Please

consider this before allowing qualified servicepersons to gain access to the machine.

CLEANING & MAINTENANCE

WARNING: Isolate the electrical connection at the wall and allow to cool prior to cleaning.

CAUTION: Steel cutting processes used in the construction of this machine can result in sharp edges. Avoid contact with sharp edges during cleaning and maintenance.

Do not clean with the use of a water jet or immerse in water.

Do **not** use caustic or abrasive cleaning products as they will damage the machine.

Empty/clean grease box regularly

Regular cleaning will prevent a build-up of oils and keep the machine looking new.

No part of this machine (with the exception of the grease box) should be immersed in water.

Wipe all surfaces of the machine with warm soapy water using a damp non-abrasive cloth.

WARNING: Some cleaning agents can damage stainless steel or the polycarbonates/plastics used in switches and pilot lights. Use only soapy water as a cleaning agent.

Ensure the unit is switched off before any servicing or inspection is carried out.

Servicing and maintenance should only be carried out by a qualified technician. It is recommended that inspections be carried out annually to ensure the appliance is in line with changing standards.

INSTALLATION

Remove all packaging materials, tape, and any protective plastic from the machine. Remove any glue residue from the protective plastic or tape using citrus cleaner.

Place the product on a firm, level surface in the desired position. Do not install within 300mm of flammable materials. The AH860 has a rear spacer to set a minimum distance from non-flammable walls that must never be removed or modified.

A minimum distance of 500mm above the cooking plate must be kept clear of any obstruction. Do not obstruct or in any way close off the front of the machine.

Install at a distance of at least 100mm from materials and leave a 100mm air gap at the front & rear of the unit. If the unit is used near combustible material, common sense should be applied to deem sufficient distancing.

Consult national standards that outline the positioning, spacing and ventilation before installation.

If this appliance is located in a row of appliances (e.g. Austheat® Fryer), ensure that adjacent machines do not restrict air flow. Failure to provide adequate air flow could result in the tripping of the thermal protective circuits within the unit.

Consideration should be given to securing the unit or limiting mobility if the unit is hard-wired. Consult appropriate standards to ensure compliance with relevant regulations.

We recommend the use of an RCD (Residual Current Device) rated at **no less than 30mA** for circuit protection. If an RCD is used to protect multiple appliances, ensure the RCD is appropriately rated so as to allow up to 30mA leakage current for this unit.

CAUTION: Do not attach any other items, machines or brackets to these units as any such alterations may change the thermal properties or safety aspects of these machines and will void any warranty.

CAUTION: In order to avoid inadvertent re-setting of the internal thermal cut-outs, ensure the appliance is not wired through an external switching devices (such as a timer), or any device that is regularly switched on and off by the utility.

ELECTRICAL CONNECTION

Before connecting the machine to the power supply, ensure that **all** switches are in the OFF position.

A licensed electrician must install this unit to comply with national installation codes and regulations. Means for disconnection from supply must be incorporated in the fixed wiring in accordance with the wiring rules.

WARNING: UNIT MUST BE EARTHED

We also advise that this unit, and any other stationary appliances, be connected to a equipotential bonding grid to eliminate any differences in electrical potential within the kitchen.

WARNING: If the electrical mains supply cabling is damaged, the machine must not be used until a qualified person has replaced the cabling and deemed the machine to be functioning properly.

There are two main supply connection points in the unit. The first is through the lower back panel at the rear of the unit. The second connection point is through the base of the machine at the rear. Both connection points have three choices of holes for the cable to pass through. Protection must be given to the mains cables if they are positioned such that they can contact the hot surfaces of the unit. **A suitable**

cable gland is required for the cable to pass through.

Each hotplate must be connected to an adequately protected power supply and an isolation switch mounted adjacent to, but not behind the Hotplate. This switch must be clearly marked and readily accessible in case of fire.

GENERAL INFORMATION

This appliance is designed as a floor mounted unit. The controls are located along the front display panel with the primary ON/OFF switch located on the lower control panel.

These units generate an extreme amount of heat, which has the capacity to adversely affect some components within the machine. These units are fitted with internal fans to provide component cooling in the upper display panel and to provide an air curtain along the grease box guide assembly. In the event of a failure of an internal fan, a safety thermostat will operate

and cut power to the machine, the result being a sudden loss of power (pilot lights extinguished).

If such a shutdown occurs, leave the unit to cool for 30 minutes and turn the unit off and back on. This electrical reset will allow the unit to begin operating again. If the unit shuts down a second time this is confirmation that the unit is overheating and you should call Roband Australia or your local electrician for service.

A strong Pest-Eradication program should be in place in any kitchen before installing this or any similar machines.

WARNING: Pouring cold water onto a hot plate will cause spitting and may result in damage to the plate.

If required, the unit can be moved by lifting from underneath the front, just above the door, and pulling it along on the rear castors.

CONTROL LAYOUT

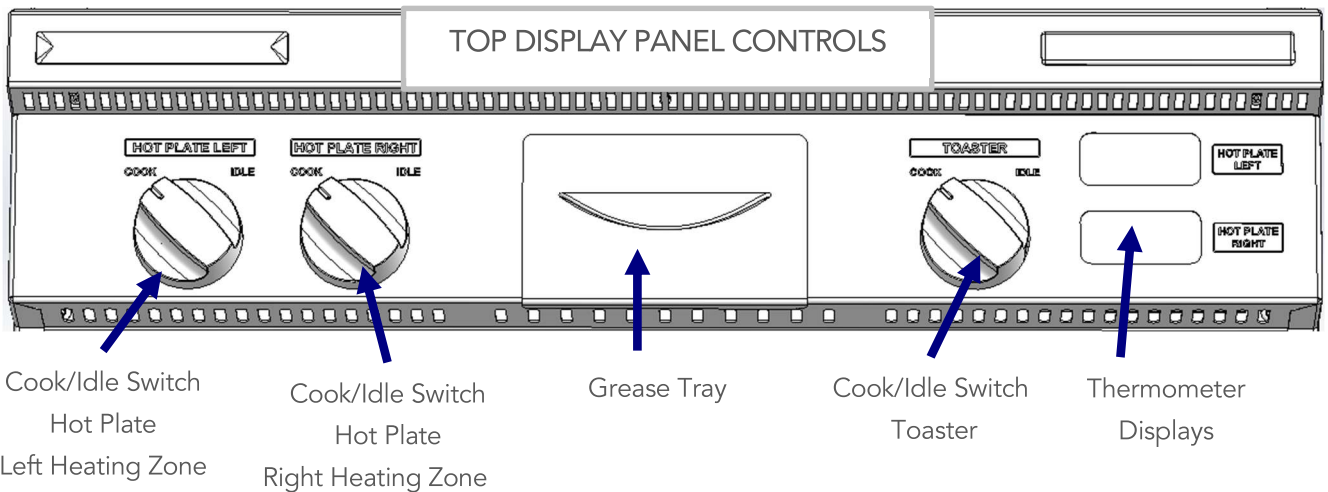

Lower Control Panel

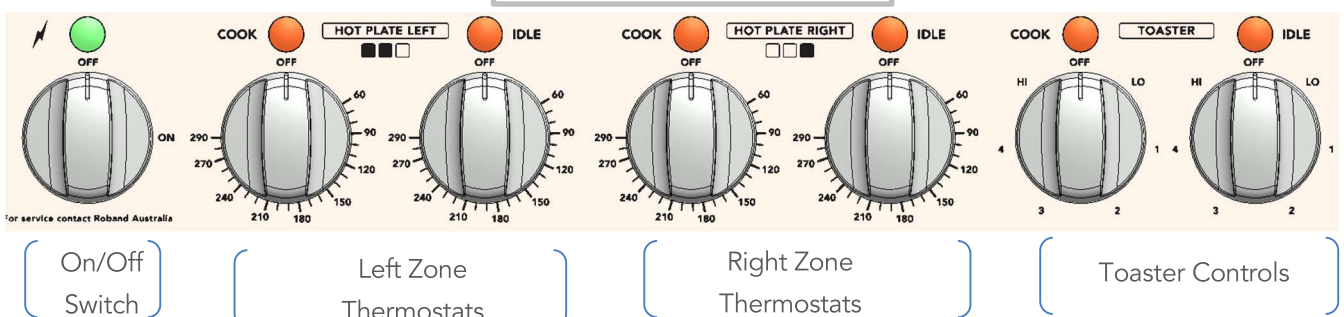

WARNING: THE ON/OFF SWITCH DOES NOT PROVIDE COMPLETE ISOLATION – refer to section: ELECTRICAL CONNECTION

CONTROL DESCRIPTION

Both the hotplate and toaster have idle/cook functions, meaning you are able to have 2 pre-set temperatures to switch between. Simply set the thermostats on the lower control panel to your desired cooking or idle (non-peak cooking period) temperatures and switch between the two during busy periods (or quiet periods) to save energy.

This appliance utilises a hotplate that can heat either the left side, right side or both sides during operation. The three elements heating the hotplate are split so that the left thermostat controls the 2 left elements, and the right thermostat controls the element on the right-hand side.

Both thermostats have a maximum temperature of 290°C as indicated on the thermostat dial.

The primary ON/OFF switch is located on the lower control panel which, when turned in the "ON" position, will illuminate the green pilot light located above the switch and signal that the unit is operational.

While the green pilot light will be constantly illuminated during operation of this appliance, the 2 orange pilot lights connected to either the left- or right-hand side controls will cycle on/off as the thermostat supplies power to the elements to maintain the predetermined temperature.

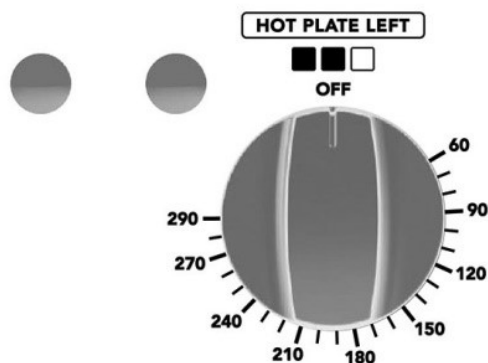

The Cook/Idle Switch allows you to quickly switch between 2 predetermined temperatures set by the lower thermostat.

Each thermostat clearly labels which operating "zone" it controls and matches up with the relevant Cook/Idle Switch.

HOT PLATE RIGHT

COOK **IDLE**



COOKING/HEATING ZONES

As previously mentioned, the hotplate is not split evenly, with the left-hand side elements heating 2/3rd of the hotplate and the right-hand side elements heating the remaining 1/3rd (as seen in the pictorial below).

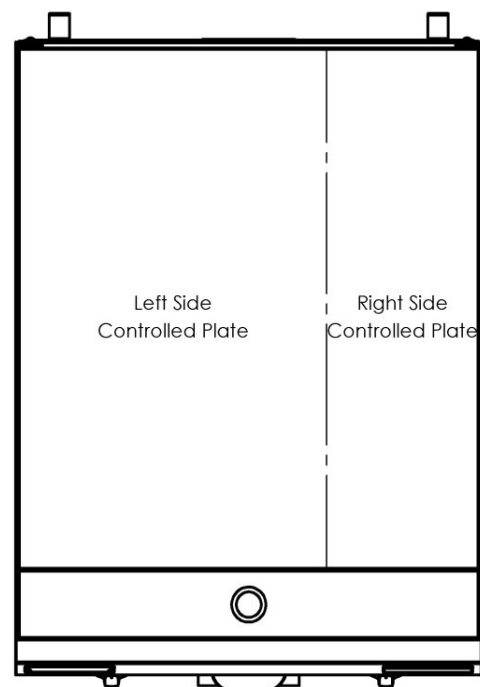

The hotplate is designed in such a way that heat pools in the centre of the hotplate, with the front and rear corners being comparatively cooler. This allows the user to balance the cooking times of

multiple products/foods that require different temperatures or times to cook.

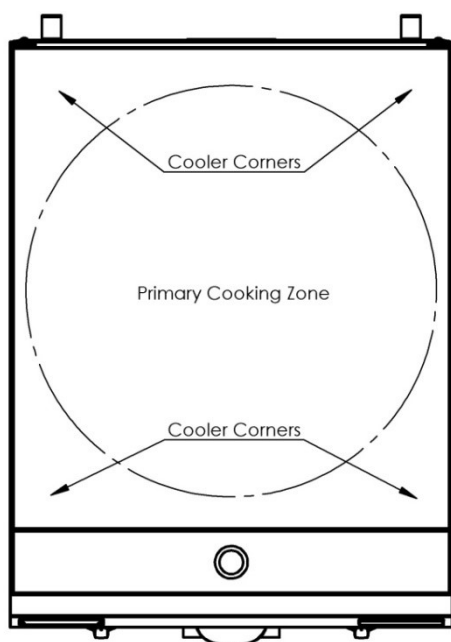

TOASTING CONTROLS

The toaster element is controlled by the two energy regulators on the lower control panel on the right-hand side. These are wired to a "Cook/Idle" switch on the upper display panel which allows switching between the two energy regulators.

It is suggested that the "Cook" energy regulator be set between 4-HIGH, and that the "Idle" energy regulator be set to 2. This will allow the elements to stay warm while using minimal power and will speed up the recovery time when the "Cook" setting is later selected. **This is only a guide and only personal use will dictate the best settings for your particular bread.**

CAUTION: Always use gloves when handling the toast rack during operation.

TEMPERATURE DISPLAY

The temperature displays can be seen on the display panel, located on the front of the hotplate on the right-hand side. It displays the real time temperature of the appropriate hotplate "heating zone".

In the event of an overheating situation, the temperature displays will also be shut down and

will not re-illuminate until the machine is turned off and back on again (after cooling down).

OPERATION

SEASONING

Before cooking for the *first time* the hotplate need to be seasoned as follows.

- ◆ Remove the paper from the plate and wipe off excess fat.
- ◆ Brush the plate liberally with frying oil and cover the surface with a layer of salt.
- ◆ Set the thermostat to a temperature of around 180° and heat for 25 minutes.
- ◆ Allow the oil and salt to cool, and then remove it carefully without scratching the surface.
- ◆ Brush the plate with oil again and re-heat until the oil is burnt in. This will form a skin on the surface of the plate.
- ◆ Re-oil the surface once again.

Your Hot Plate is now ready for use. Be sure to never clean the hotplate using cleaning agents (only soapy water) as this can strip back the seasoning layer that has formed and can damage the plate.

COOKING

1. Rotate the main switch to the "ON" position, the green pilot light will illuminate, indicating power is on.
2. Rotate thermostats to desired cooking/idle temperature. Once set, the amber pilot light associated with each side will illuminate until the temperature is reached and will turn off.
3. Once the amber pilot light switches off, cooking may commence (temperature has been reached). Notice the amber pilot light will cycle on/off in sync with when the thermostat energises the elements.
4. When finished with the appliance, ensure both thermostats are set at "OFF" and primary switch is in the "OFF" position.

TOASTING

Models purchased with the Toaster/Grill also have the advantage of a grilling / toasting rack which can be used at any time, regardless of whether or not the Plate is being used.

The toasting rack is placed on the runners and can be used in any of the different height positions to produce satisfactory results.

In all cases these units should be given sufficient time to reach the set temperature before cooking commences.

FIRST TIME OPERATION – “OFF-GASSING”

The toaster unit uses insulation materials within the body of the machine. When heated for the first time, the insulation will release some small amount of vapour (commonly referred to as “Off-Gassing”). For this reason, we recommend that operators run the machine with all controls in their highest setting for at least an hour before operating. Note that the vapours produced may sting the eyes of anyone leaning over the Display Panel.

The Off-gassing will typically last no more than an hour, and, once the off-gassing process is complete, no further off-gassing will occur unless the unit overheats. In a fault condition, where the machine overheats, some additional off-gassing may occur before the unit’s safety over-temperature device cuts the power.

The gaseous vapours emitted in the “off-gassing” period are non-toxic. They have a slightly unpleasant smell and may sting the eyes if in very close proximity.

WORKSATION LAYOUT

Roband Australia recommends that areas between this unit and other machines and/or work-surfaces be kept clear of any potential obstacles or trip hazards. Work areas should also be cleaned and floors should be oil-free to reduce the likelihood of slipping.

It is anticipated that these machines will be operating beneath a suitable exhaust/extraction unit to reduce the ambient temperatures around the operator.

TROUBLESHOOTING

If the Hotplate does not function check the following points before calling for service.

- ✓ The power is switched “on”, both on the unit and at any other point that supplies power to the machine (e.g., an isolating switch on the wall).
- ✓ The mains power is not faulty.
- ✓ The temperature has been set correctly and the thermal cut-out has not tripped. Refer to the “Thermal Cut-Out” section previous for more information on this control.
- ✓ The thermostat knobs are not loose or broken, rendering the thermostats inoperable.
- ✓ The circuit breakers located inside the lower section of the unit are all in the “on” position”. These are located behind a cover panel.

Typical issues that can be easily identified can be listed below:

1.1 Symptom – All power shut off

1.2 Check – Is air still flowing through the grease box guide?

1.3 Probable Cause – (If Yes) – Overtemp has cut out. Let machine cool for 30 minutes before switching back on. (If no) – Possible failure of primary fan or ON/OFF switch

2.1 Symptom – Plate takes too long to heat/cook

2.2 Check – All circuit breakers are in the “ON” position

2.3 Probable Cause – If tripped, there could be possible element failure. Reset circuit breakers and operate as normal. Call for service if they trip again.

3.1 Symptom – Grinding noise coming from inside the unit

3.2 Check – Does it sound like a fan turning but being noisy?

3.3 Probable Cause – Internal fan bearing may be failing. Call for servicing before the fan fails, as such a failure will cause the machine to overheat and shut down.

THERMAL CUT-OUTS

These units are fitted with an internal safety thermostat designed to cut power if the internal temperatures reach a point where other components may be damaged. There are several possible situations that may cause the safety thermostat to cut out, such as a cook thermostat failure or the failure of an internal fan. You may follow the procedure below as a first step to rectifying the problem.

1. Switch the Hotplate OFF using the main On/Off switch and allow it to cool for approximately 30 minutes.
2. Switch the unit back on – operation can now continue as normal.
3. Repeat steps 1 and 2.
4. If the unit again trips out it may be the result of a failure in an internal fan - phone for service.

If the Hotplate continues to perform without any further tripping of the thermal cut-out after step 3, then there is a strong possibility that the thermostat in use at the time is faulty, or that one of the internal cooling fans is no longer functioning. This should be attended to by qualified electrical personnel.

If the machine trips the thermal cut-out a second time, switch the unit off and refrain from further use until the unit has been repaired. Continuing to use the machine may cause premature failure of other components if repeatedly exposed to over-temperature situations.

SPARE PARTS

EC0831	Circuit Breaker – 32A	MC0610	Castor
ES0283	On/Off Switch	MC0649	Toasting Rack
EC0427	Rail Mounted Terminal Block Red	PC0276	Bush – 1 3/8" Nylon 6/6
EC0428	Rail Mounted Terminal Block Blue	PC0287	3/4" Plastic Knockout Plug
EC0247	Rail Mounted Terminal Block Earth	PC0288	1" Plastic Knockout Plug
EC0832	Circuit Breaker – 13A	PC0379	Bush – 1 3/8" Nylon 6/6 – Slotted Face
EC0827	Contactactor – 2 Pole – 25A	SS2204	Crumb Tray/Reflector
EC0804	Fan – Tangential – 18W	SS2219	Circuit Breaker Cover
ES0264	Amber Pilot Light Assembly	TC0033	Thermal Cutout - 60°C – N/O
ES0265	Green Pilot Light Assembly	TC0035	Thermal Cutout - 70°C – N/C
HC0141	Element – 125W 230VAC	TS0030	Thermostat 290°C Pan Assembly
HC0174	Element – 3500W 230VAC	VS0374	Grease Box & Handle Complete
MC0093	Clamp - Cable	VS0395	Digital Temperature Display
MC0609	Adjustable Leg		

CIRCUIT DIAGRAM

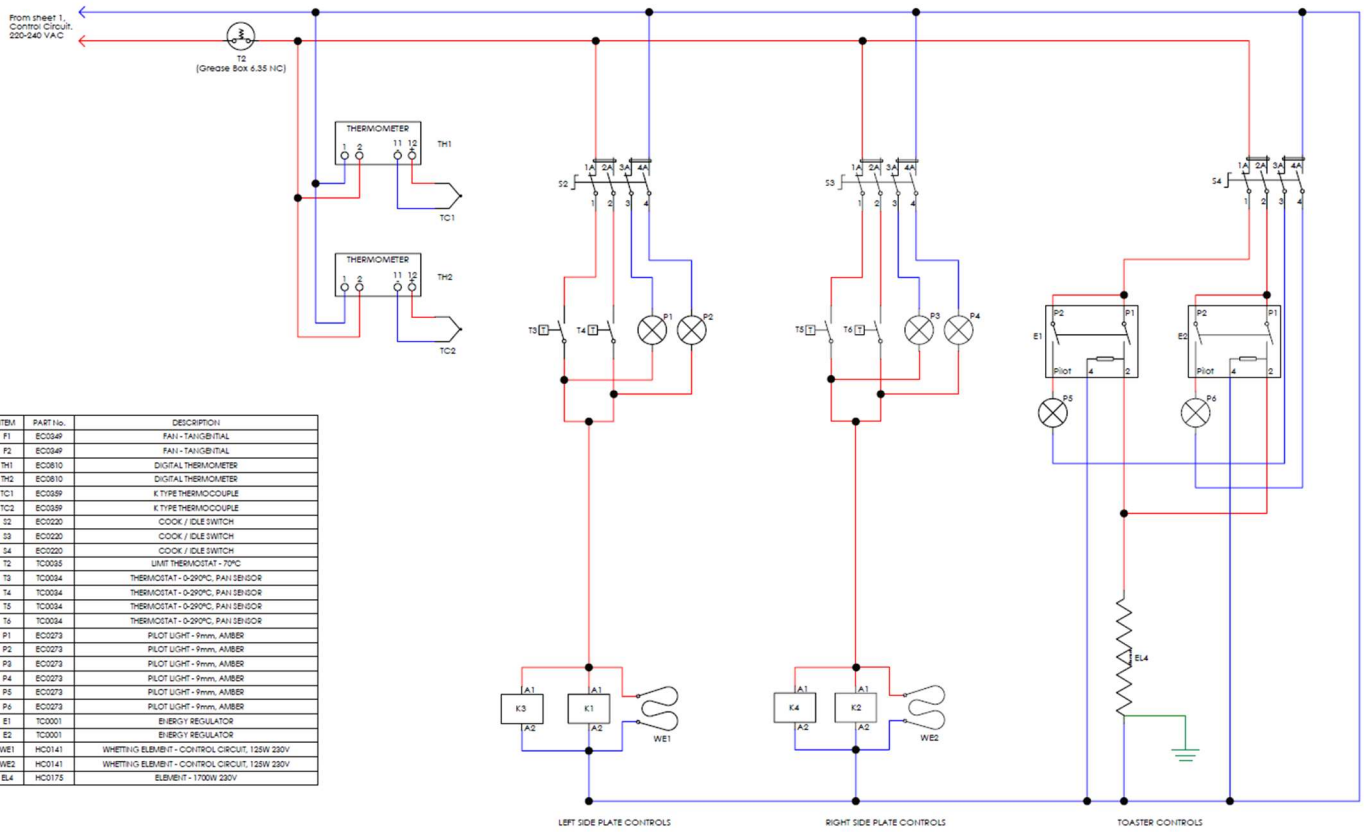
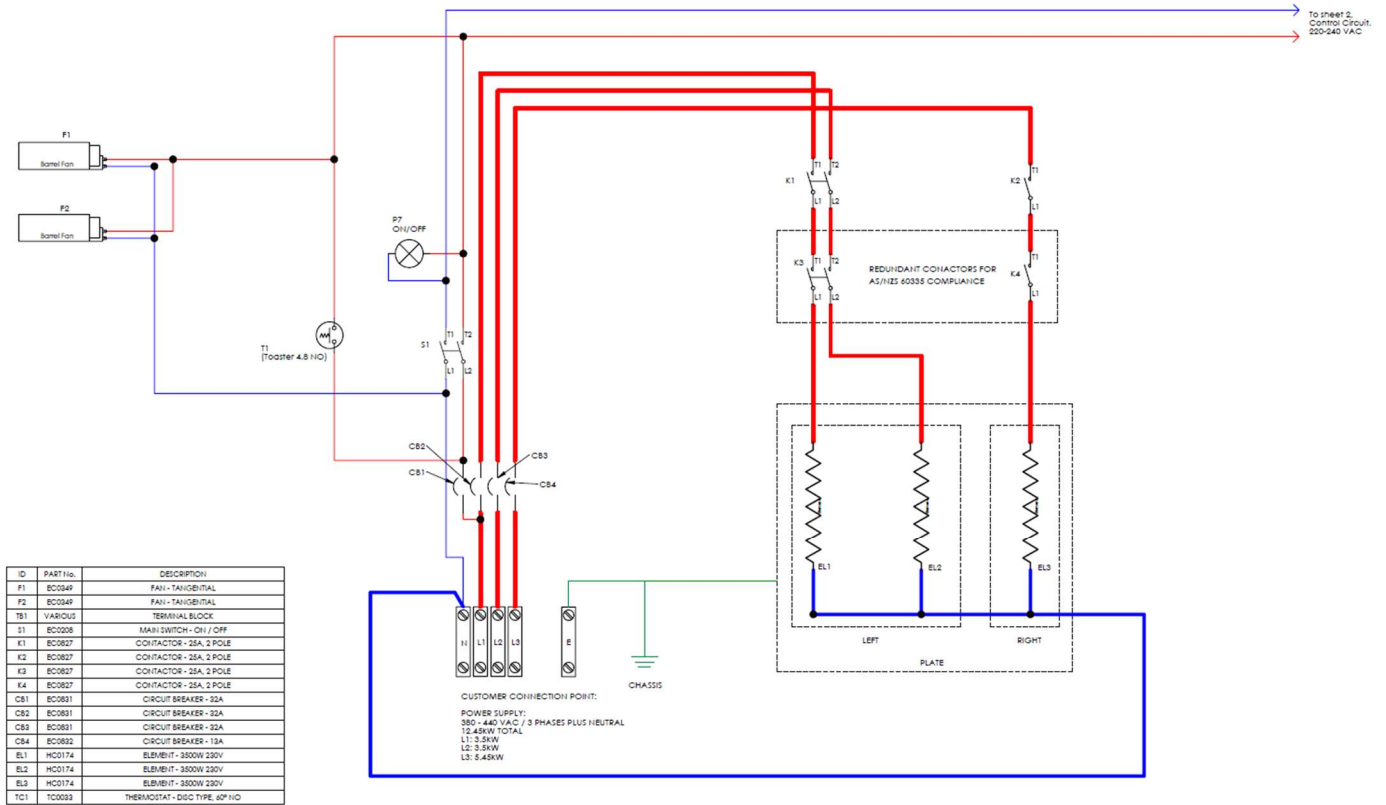

WARRANTY

The warranty conditions set out below are in addition to any warranties implied or governed by law.

Roband Australia warrants that this appliance shall be delivered free from defects in material and workmanship. The warranty for this product is offered to the original purchaser, to be free of fault in both workmanship and materials for a period of 12 months from date of purchase. Roband's obligations pursuant to this warranty are limited to the repair or replacement of the defective goods or materials, at its discretion and subject to the terms contained within this Warranty statement.

The following conditions apply:

The product must be installed, maintained and used under normal operating conditions within the scope of the operating instructions.

All warranty claims must be submitted to Roband or an authorised Roband dealer, and Roband authorisation must be granted prior to repairs being carried out. Proof of purchase is required for any repair authorisation.

Warranty is back to base, meaning delivery to and collection of your product to Roband or an authorized service agent is the responsibility of the purchaser.

Where a product cannot be returned back to base, on-site warranty can be arranged by prior agreement.

The following exclusions apply:

Claims or faults arising from misuse, neglect, transport damage or other mechanical damage, including but not limited to; door's, hinges & interlock switches etc., other than those arising from manufacture or material defects. Where relevant, glass, Teflon® and lamps are not included in this warranty and RCD tripping due to moisture absorption by Tubular Heating Elements is not a warranty fault.

Roband or any subsidiary company or Agent shall not be liable for loss of profit or damage to other equipment and property except where it is in breach of the guarantees provided in accordance with applicable legislation.

Roband reserves the right to reject a warranty claim if it is not satisfied with the circumstances under which the fault occurred or where a product has been altered from its original specification.

For on-site repairs outside of capital city metropolitan areas, travel costs, service callout fee and related labour costs etc. are the responsibility of the claimant.

Any costs incurred for false claims or faults due to incorrect usage etc. are the responsibility of the claimant.

Any attempt to repair the product by non-Roband approved service personnel or the use of non-genuine parts will void the warranty agreement

Our goods come with guarantees that cannot be excluded under the Australian Consumer Law. You are entitled to a replacement or refund for a major failure and compensation for any other reasonably foreseeable loss or damage. You are also entitled to have the goods repaired or replaced if the goods fail to be of acceptable quality and the failure does not amount to a major failure.

Extended Warranty;

You are entitled to a five (5) year extended warranty on the fryer tank, a two (2) year extended warranty on parts, in conjunction with one (1) year labour coverage.

The extended warranty application form on the Roband website must be completed and submitted to Roband within 30 days of purchase.

For the name of your nearest Australian authorised service agent, please contact:

Roband Australia Pty Ltd
1 Inman Road,
Cromer, NSW, 2099, Australia
Warranty: 1800 268 848
Tel: +61 2 9971 1788
Email: sales@roband.com.au
Web: www.roband.com.au

For your nearest International distributor,
please visit:
<https://www.roband.com.au/worldwide/>