



**Model**

MSS350A

**Product Description**

Slicer, 350mm, Semi-automatic,  
Extra Heavy Duty, Stainless Steel

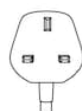

**Standard Features**

- High-quality, stainless-steel, semi-automatic gravity feed slicer with 350mm blade
- Corrosion resistant, made entirely of AISI 304 stainless steel
- 100% waterproof with an IP67 protection rating
- Reliable operation and easy to clean thanks to an ergonomic design with a removable carriage
- Very rigid structure
- Slice thickness adjustable with great precision from 0-25mm
- High performance gear transmission
- Easy to use independent sharpener: a simple turn of the graduated knob allows perfect sharpening; an operation that can be performed easily and quickly by any operator
- The carriage slides smoothly, thanks to the well-structured gliding system
- The sturdiness and quality of the components, together with their careful assembly, guarantee a perfect cut
- The plate assembly and blade guard are dishwasher-safe
- Equipped with a single-phase motor of 0.64HP
- UL, NSF & CSA certification
- CE Approved

**Drawing**

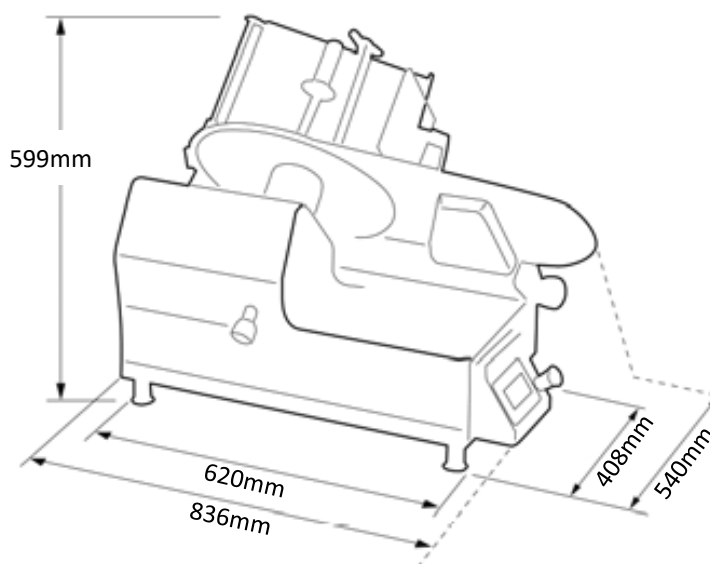

## Specifications

Model	MSS350A
Blade Size (mm)	350
Duty	Extra Heavy Duty
Feed Type	Gravity
Suitable for Cured Meats	No
Cutting Capacity (mm)	<ul style="list-style-type: none"> <li>● 252</li> <li>□ 300 x 181</li> </ul>
Max Slice Thickness (mm)	0 - 25
Phase (Ø)	Single
Voltage (V)	230
Frequency (Hz)	50
Power (kW / hp)	0.47 / 0.64
Power Connection	13 Amp plug
Items Included	Knife Remover Screwdriver Tasteless Oil
Max Overall Dimensions D x W x H (mm)	540 x 836 x 599
Net Weight (Kg)	68
Packed Dimensions D x W x H (mm)	790 x 850 x 720
Packed Weight (Kg)	78
Volume (m3)	0.48
Warranty	Metcalfe 2-year warranty (1 <sup>st</sup> year parts and labour, 2 <sup>nd</sup> year parts only) and full after sales service

We reserve the right to alter the specification and technical details for this item at any time without prior notice.

4/2026

### Metcalfe Catering Equipment Ltd

Haygarth Park  
 Blaenau Ffestiniog  
 Gwynedd, LL41 3PF

