



Model

MP10G

Product Description

Planetary Mixer, 10 litre, Heavy Duty

Product Code

5MP10G

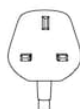

Standard Features

- Heavy duty 10ltr, countertop, gear driven, planetary mixer
- Particularly suitable for bakeries, hotels, restaurants, canteens etc
- Easy to operate
- Planetary mixing action and digital timer ensures perfect results
- High torque motor allows mixing of stiffer doughs and larger batches
- 30 minutes timer
- Digital control panel
- 3 fixed speeds: 122, 219 and 430 rpm
- Easy speed-shifting
- Interlocking bowl guard and bowl lift
- Perspex safety guard with ingredient chute and automatic shut-off when guard is opened at any speed
- Overload protection (NVR device)
- Long lasting lubricant providing abrasion resistant transmission
- All metal and die-cast aluminium body
- Non-slip rubber base
- Quiet operation
- Covered by Metcalfe 3-year warranty (1st year parts and labour, 2nd & 3rd years parts only) and full after sales service

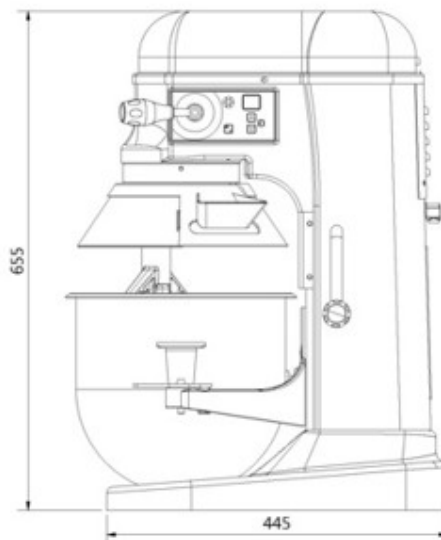
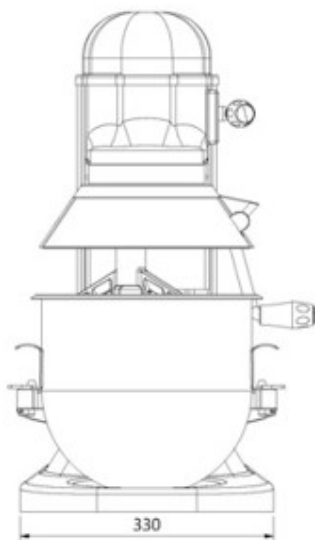
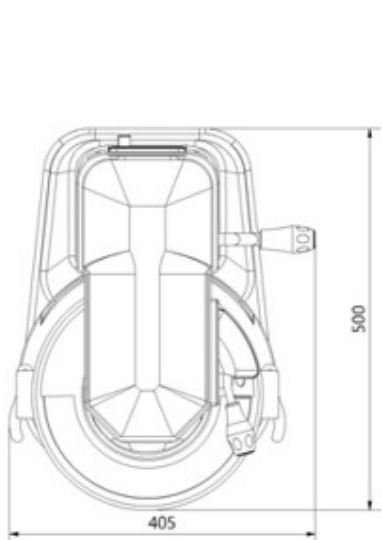

Specifications

Model	MP10G
Product Code	5MP10G
Bowl Capacity (l)	10
Duty	Heavy duty
Speed (rpm)	3 fixed speeds 122 / 219 / 430
Belt or Gear Driven	Gear driven
Location	Low bench
Attachment Hub	No
Timer	Yes (30 min, digital)
Phase (∅)	Single
Voltage (V)	230
Frequency (Hz)	50
Current (Amp)	1.7
Power (kW / hp)	0.375 / 0.5
Power Connection	13 Amp (3 Pin Plug)
Items Included	Bowl (MPGM12-12-001) Beater (MPGM12-12-001) Dough Hook (MPGM12-12-003) Whisk (MPGM12-12-004)
Optional Accessories	No
Overall Dimensions D x W x H (mm)	500 x 405 x 655
Net Weight (Kg)	32
Packed Dimensions D x W x H (mm)	580 x 500 x 750
Packed Weight (Kg)	35
Volume (m3)	0.218
Warranty	3 year (1 st year parts and labour, 2 nd & 3 rd years parts only)

Note: The minimum requirement for all electrical equipment's correct operation is an air temperature of between +5°C and +40°C. Mixers should not be operated in a cold store.

We reserve the right to alter the specification and technical details for this item at any time without prior notice.

3/2026

Metcalf Catering Equipment Ltd

Haygarth Park
Blaenau Ffestiniog
Gwynedd, LL41 3PF

